

AD14S FREESTANDING DISHWASHER 600MM



- Stainless steel finish
- 14 Place settings
- 5 wash programs: *Prewash, 30min, eco, intensive quick, and intensive*
- Fast 30 minute wash option
- Adjustable top basket
- Adjustable mug shelves
- Overflow safety
- Rinse aid indicator
- Micro filters
- Made in Europe

Total Power: 1900 - 2200 watts
 Heating Element: 1800watts
 Amps: 10amps
 Power: 220 - 240 volt/50Hz
 Water Rating: 3.5 star
 Energy Rating: 3 star
 Noise level: 54dBA

Dimensions & Installation

Product Dimensions: 598mm (W) x 600mm (D) x 850mm (H)

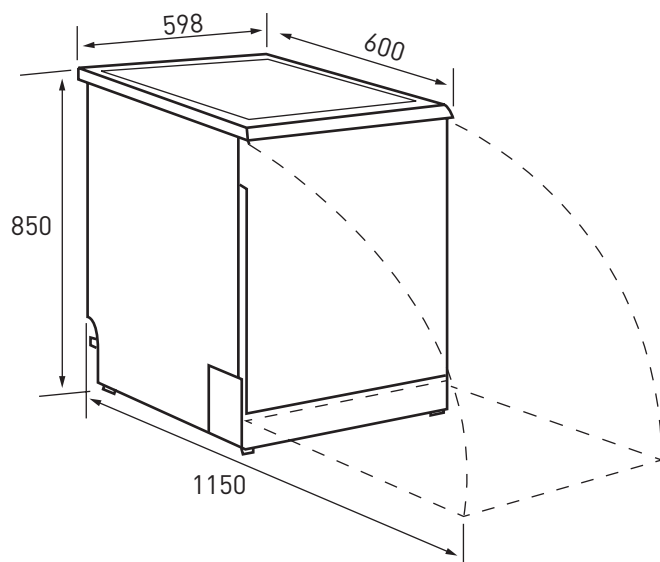

Dimensions are a guide only refer to the instruction manual and website for full instructions

warranty - customer service

Warranty

2 years Parts and Labour

Customer Service

Our Nationwide Service Team can be contacted on our Toll Free Customer Service Number 1800 805 300 or by logging on to <http://customersupport.hapl.com.au/>

HOME APPLIANCES

20 Carlotta Street
 Artarmon NSW 2064
 T: 02 9958 3111
 F: 02 9958 3555
 E: info@hapl.com.au

www.arcappliances.com.au