

CANOPY RANGEHOOD

900mm

CP9BLS



- Stainless Steel
- 700m³/hr
- Ducted operation
- Re-circulating operation optional*
- 3 speed fan, electronic backlit button
- 3 x Baffle filters for easy cleaning - dishwasher safe
- 2 x 3 watt LED lamps cooler and longer lasting

features

specifications

Airflow:	700m ³ /hr	Carbon Filter:	AXFC1
Noise level:	57 dBA on maximum setting	Extension Flue:	IASXSE3 (900mm)
Lighting:	2 x 3 watt LED		
Total wattage	196 Watts		
Power:	220 -240 volt / 50Hz (fitted with 10amp, 3 pin plug)		
Power Cord:	1.5 metre cable		
Ducting Spigot size:	150mm		
Recirculating Kit*:	IA150BSRK		

dimensions

Product Dimensions 900mm (W) x 645-1025mm (H) x 500mm (D)

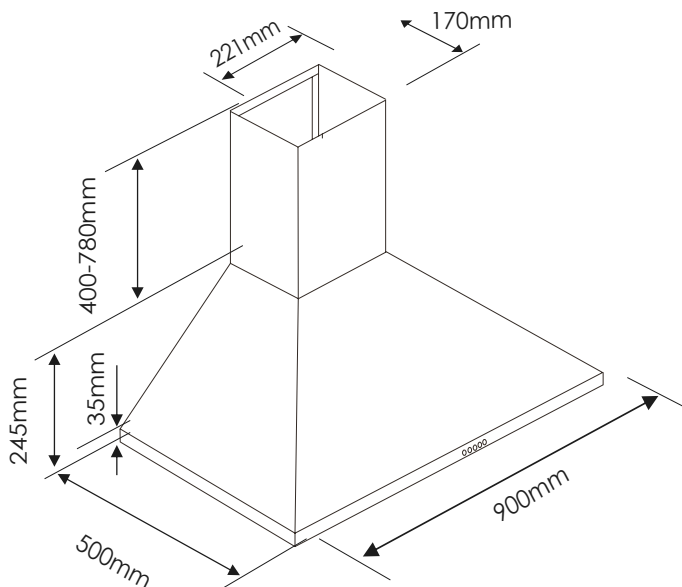

warranty - customer service

Warranty

2 years Parts and Labour

Customer Service

Our Nationwide Service Team can be contacted on our Toll Free Customer Service Number 1800 805 300 or by logging on to <http://customersupport.hapl.com.au/>

 **HOME APPLIANCES**

20 Carlotta Street
 Artarmon NSW 2064
 T: 02 9958 3111
 F: 02 9958 3555
 E: info@hapl.com.au

www.hapl.com.au