

GAS COOKTOP

600mm

ICD6SG4



- Stainless Steel
- Cast Iron Pan Supports
- One Piece Stainless Steel Panel
- Electric Ignition
- Front Position Control Knobs
- Flame Failure Safety Device

features

specifications

Natural Gas:	30.5 Mj/h
Propane:	29.5 0Mj/h
Power:	220-240 volt / 50Hz
	10amp 3 pin plug

Front Left - Triple Ring Wok Burner	14 Mj/h
Front Right - Auxiliary Burner	4.5 Mj/h
Rear Left - Semi Rapid Burner	6.0 Mj/h
Rear Right - Semi Rapid Burner	6.0 Mj/h

dimensions

Dimensions:	580mm (L) x 510mm (B) x 90mm (D)
Cut out Dimensions:	555mm (L) x 473mm (B) x 40mm (D)

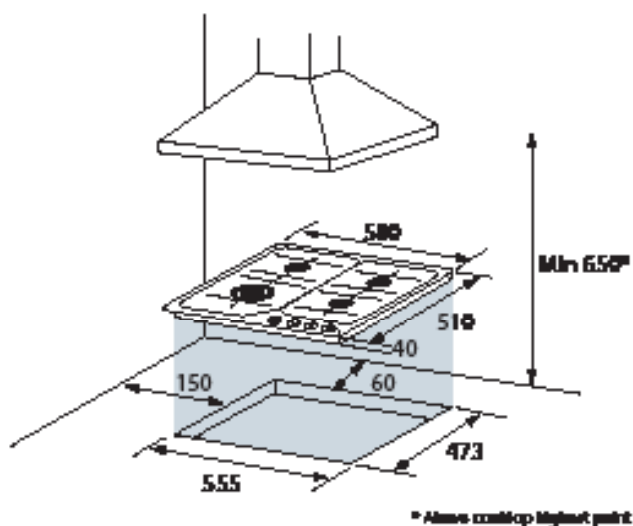

warranty - customer service

Warranty

2 years Parts and Labour

Customer Service

Our Nationwide Service Team can be contacted on our Toll Free Customer Service Number 1800 805 300 or by logging on to <http://customersupport.hapl.com.au/>

HOME APPLIANCES

20 Carlotta Street
 Artarmon NSW 2064
 T: 02 9958 3111
 F: 02 9958 3555
 E: info@hapl.com.au

www.hapl.com.au