

MICROWAVE

520mm

IM30SE3



- Stainless steel
- 30 litre capacity
- 315mm glass turntable
- 20 watt light
- 5 cooking modes
- LED display
- 60 minute timer
- Memory function
- Child lock
- Optional trim kit available

features

specifications

| | |
|------------------------|--|
| Microwave output: | 900 watts |
| Microwave levels: | 900W, 630W, 450W, 300W & 90W |
| Power requirement | 220-240V / 50 Hz |
| Electrical Connection: | Fitted with 1 metre flexible cable with 3 pin plug |



IM30SE3 pictured with IMI30ST3 trim kit

dimensions

| | |
|------------------|-----------------------------------|
| Dimensions: | 520mm (W) x 430mm (D) x 300mm (H) |
| Internal cavity: | 350mm (W) x 372mm (D) x 232mm (H) |

warranty - customer service

Warranty

2 years Parts and Labour

Customer Service

Our Nationwide Service Team can be contacted on our Toll Free Customer Service Number 1800 805 300 or by logging on to <http://customersupport.hapl.com.au/>

HOME APPLIANCES

20 Carlotta Street
Artarmon NSW 2064
T: 02 9958 3111
F: 02 9958 3555
E: info@hapl.com.au

www.iagappliances.com.au

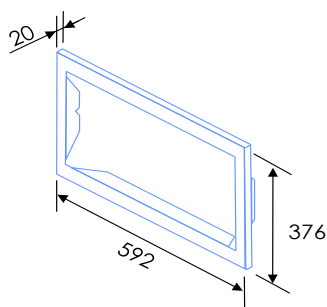

IMI30ST3 Trim Kit dimensions

Figure 1 Building - In Cabinet requirements

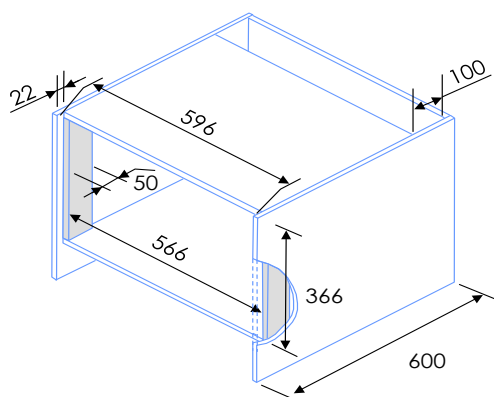

Note: Minimum space requirement around microwave oven is 40mm on top and rear back and 20mm on sides