

# OVENS

600mm

## IOF6SE3



features

- Fully programmable clock
- Allows cooking to be programmed
- 5 function programmer
- Defrost option
- Defrost using the fanned air
- Fast consistent oven heating and controlled cooking
- Grill with door closed
- Ventilated oven door
- Locking oven shelves
- Touch proof stainless steel external finish
- Finger and hand prints do not show on surface
- Safety feature to prevent shelves from accidentally falling out. Shelves must be tilted to be removed
- Safety feature to reduce surrounding temperature in cabinets and prolong life of oven components
- Safety feature to reduce heat transfer to external glass panel

## specifications

### Functions:



Fan forced cooking



Fan forced cooking and grill



Grill function



Oven light



Defrost

**Total Load:** 2.56kW (15amp connection)

**Power:** 220-240 volt/50Hz

## dimensions

**Product Dimensions:** 594mm (W) x 594mm (H) x 571.5mm\* (D)  
(\*includes 28.5mm control panel)

**Cut Out Dimensions:** 558mm (W) x 575 - 585mm (H) x 550mm (D)

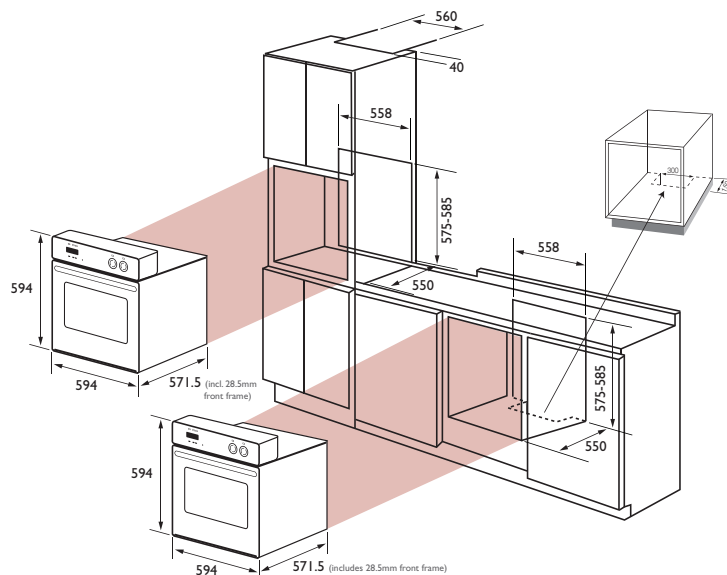

warranty - customer service

### Warranty

2 years Parts and Labour

### Customer Service

Our Nationwide Service Team can be contacted on our Toll Free Customer Service Number 1800 805 300 or by logging on to <http://customersupport.hapl.com.au/>

**HOME APPLIANCES**

20 Carlotta Street  
Artarmon NSW 2064  
T: 02 9958 3111  
F: 02 9958 3555  
E: [info@hapl.com.au](mailto:info@hapl.com.au)

[www.hapl.com.au](http://www.hapl.com.au)