

SLIDEOUT RANGEHOOD

600mm

RSFR8S (stainless steel fascia panel)



- Stainless Steel front fascia panel 80mm with grey end caps
- 440m³/hr
- Twin motor
- Front recirculating
- 3 speed fan, controlled by slide switches
- 2 x Aluminium grease filters washable, 1 with charcoal inlay
- 2 x 40 watt halogen lamps

features

specifications

Airflow:	440m ³ /hr	Carbon Filter: CF110
Noise level:	56 dBA on maximum setting	
Lighting:	2 x 40 watt halogen	
Motor wattage	120 watt	
Power:	240 volt / 50Hz (fitted with 10amp, 3 pin plug)	
Power Cord:	1.5 metre cable	
Ducting Spigot size:	120mm	

dimensions

Product Dimensions 600mm (W) x 175mm (H) x 280 - 450mm* (D)

Cut Out Dimensions 553mm (W) x 135mm (H) x 280mm[#] (D) ([#] cabinet only)

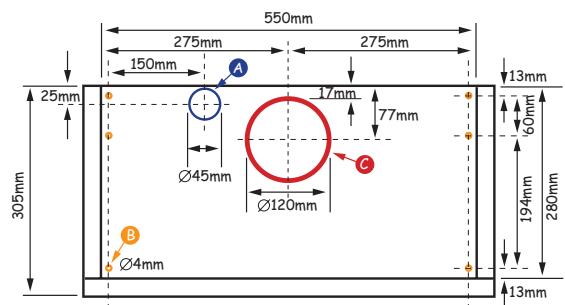
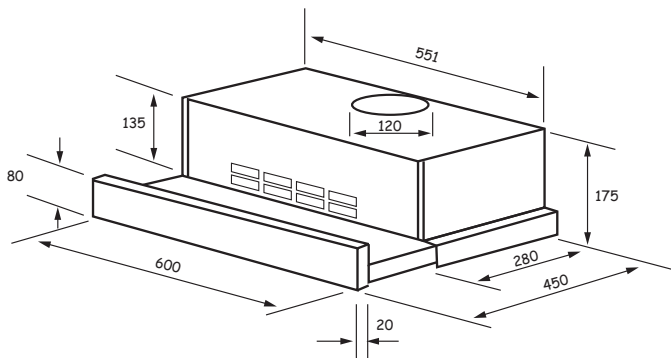

- A** Hole x 1 = position and size (45mm dia.) in shelf above rangehood for power cord
- B** Holes x 6 = position and size (4mm dia.) in shelf above for fixing of hood with washers and screws supplied
- C** Hole x 1 = position and size (120mm dia.) in shelf above for ducting pipe

Warranty
2 years Parts and Labour
Customer Service

Our Nationwide Service Team can be contacted on our Toll Free Customer Service Number 1800 805 300 or by logging on to <http://customersupport.hapl.com.au/>